

A B C D E F G H J K L M N P

1
2
3
4
5

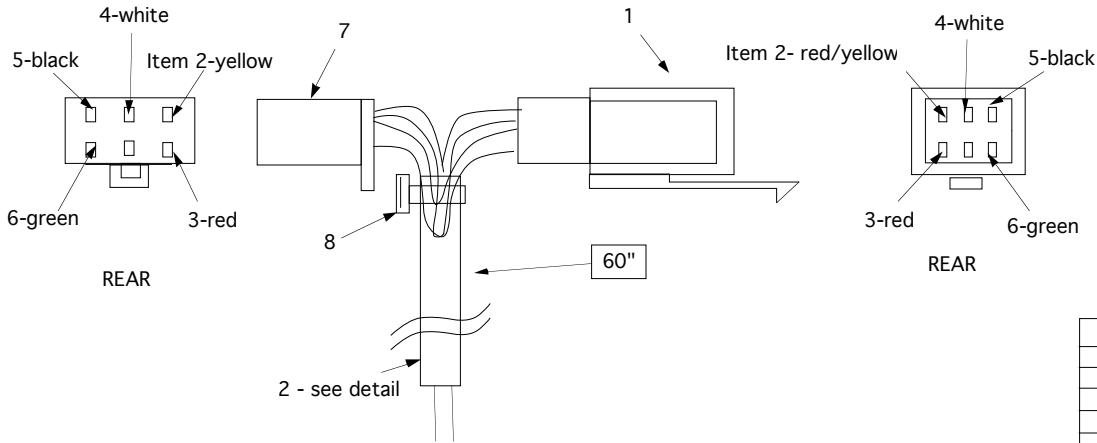

Rev	Description	by	Date
0	Release		

8	30501	1	ea	Tie wrap, 4"
7	85562	1	ea	Jack, Hondaline, brown
6	85326	1	ea	Jumper, HLC, green
5	85325	1	ea	Jumper, HLC, black
4	85324	1	ea	Jumper, HLC, white
3	85607	1	ea	Jumper, HLC, red
2		1	ea	Harness sub assy - See detail
1	85561	1	ea	Plug, Hondaline, brown
Item	p.n.	Qty.	unit	Description

DETAIL- HARNESS SUBASSY

6
7
8
9

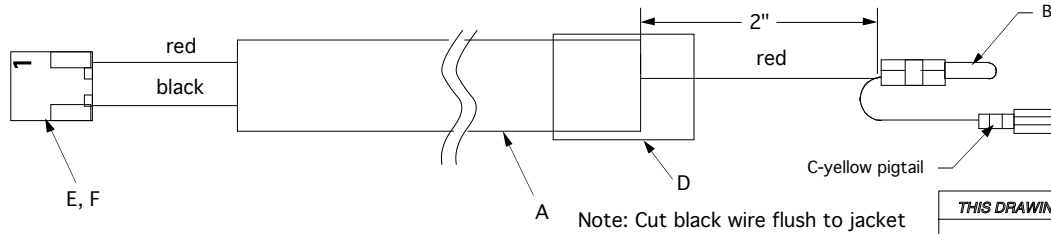

Note: Cut black wire flush to jacket

G				
F	40119	2	ea	Contact, pin, microfit, 20-24 AWG
E	40114	1	ea	Plug, 2 conductor, microfit
D	30057	1	in	Tubing heat shrink, 3/16
C	85362	1	ea	Pigtail, yellow
B	40067	1	ea	Contact, pin, hitachi type
A	90019	60	in	Cable, 2 conductor, 22AWG, gray
Item	p.n.	Qty.	unit	Description

THIS DRAWING IS THE PROPERTY OF THE KENNEDY TECHNOLOGY GROUP, ROSE HILL, KANSAS

Kennedy Technology

UNLESS OTHERWISE SPECIFIED:
DIMENSIONS ARE IN INCHES
TOLERANCES
LINEAR
Fractional - 1/32"
0.0 ± 0.15
0.00 ± 0.015
0.000 ± 0.0015
ANGULAR
±0.5 DEG.

REFERENCE	95325			Harness, PTT interface, 1500		
SIZE	CADFILE	DWG NO.	REV NO.	EFFECTIVE	sn:	
B		95330	0			
SCALE: NONE			FOR ASSISTANCE CONTACT:		DRAWN	DATE
SHEET 1 OF 1			voX 316-776-1111 fax 316-776-9035		CHECKED	DATE

A B C D E F G H J K L M N P