

A B C D E F G H J K L M N P

| Rev | Description | by | Date |
|-----|-------------|----|---------|
| 0 | Release | jj | 06/2/06 |

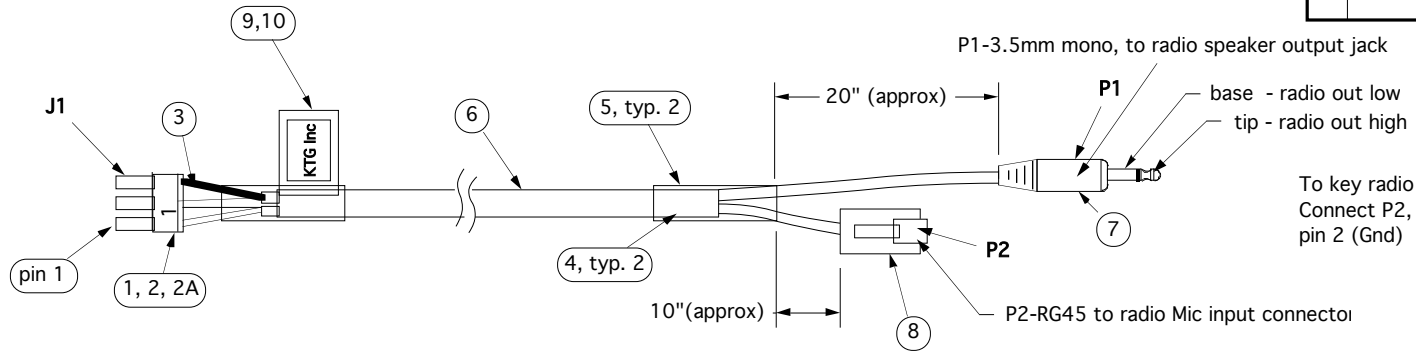

To key radio transmitter:
Connect P2, pin 3 (PTT) to P2,
pin 2 (Gnd)

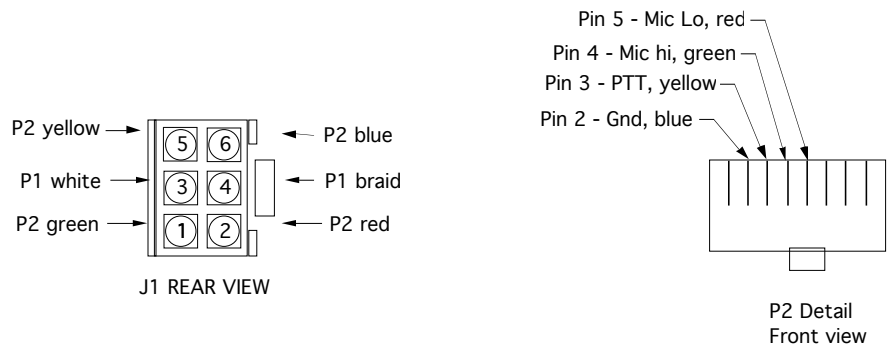

| 13 | | | | | |
|------|-------|-----|------|------|----------------------------------------------|
| 12 | | | | | |
| 11 | | | | | |
| 10 | 60172 | 0 | 1 | ea | label, radio harness, T2800 |
| 9 | 60049 | 0 | 1 | ea | label, laminating |
| 8 | 40030 | 0 | 1 | ea | Corset, RG45, black, single end |
| 7 | 40050 | 0 | 1 | ea | Cordset, plug, 3.5mm, mono, straight, 72" |
| 6 | 30624 | 0 | 57 | in | Sleeve, polyester, 3/8", black, non-fray |
| 5 | 30029 | 0 | 3 | in | Tubing, heat shrink, 3/8" |
| 4 | 30200 | 0 | 0.2 | mL | Adhesive |
| 3 | 30049 | 0 | 1.5 | in | 1/16" heat shrink |
| 2A | 40118 | 0 | 1 | ea | Terminal, Female, Micro-fit, Gold, 20-24 AWG |
| 2 | 40153 | 0 | 5 | ea | Terminal, Female, Micro-fit, Gold, 26-30 AWG |
| 1 | 40154 | 0 | 1 | ea | Receptacle, Micro-fit, 6-circuit |
| Item | p.n. | Rev | Qty. | unit | Description |

J1 Reference

| Pin | Signal |
|-----|--------------|
| 1 | Mic Hi |
| 2 | Mic Lo |
| 3 | Radio Out Hi |
| 4 | Radio Out Lo |
| 5 | PIT Hi |
| 6 | PIT Lo |

NOTES:
1. DO NOT CRIMP TINNED WIRE
2. CRIMP THE BRAID WIRE WITH TERMINAL 40118

THIS DRAWING IS THE PROPERTY OF THE KENNEDY TECHNOLOGY GROUP, ROSE HILL, KANSAS

Kennedy Technology

UNLESS OTHERWISE SPECIFIED:
DIMENSIONS ARE IN INCHES
TOLERANCES
LINEAR
Fractional - 1/32"
0.0 ± 0.15
0.00 ± 0.015
0.000 ± 0.0015
ANGULAR
±0.5 DEG.

| | | |
|--------------|-------------------------|-----------------------------|
| REFERENCE | 95264, 85541 | RADIO HARNESS ASSY, FT-857D |
| SIZE | B | CADFILE |
| DWG NO. | 95410 | REV NO. |
| REV NO. | 0 | EFFECTIVE |
| SCALE: NONE | FOR ASSISTANCE CONTACT: | sn: |
| SHEET 1 OF 1 | voX 316-776-1111 | DRAWN |
| | fax 316-776-9035 | CHECKED |
| | | DATE |

A B C D E F G H J K L M N P